



Single room heat recovery
air handling units

KOMFORT Ultra D105

KOMFORT Ultra D105-A

Air capacity – up to 106 m³/h
Heat recovery efficiency – up to 76 %

Application

- Air handling units for efficient supply and exhaust ventilation in flats, houses, cottages and other buildings.
- Heat recovery minimises ventilation heat losses.
- Controllable air exchange for creating the best suitable indoor microclimate.
- Compatible with round Ø125 mm air ducts.

Design

- The compact casing is made of double-skinned aluzinc panels, internally filled with 15 mm PE foam film layer for heat and sound insulation.
- The casing has mounting angles for easy installation.
- The spigots for connection to the air ducts are located at the side of the unit and are rubber sealed for airtight connection to the air ducts.
- The supply and exhaust spigots are equipped with backdraft dampers.
- The hinged side panel of the casing ensures easy access to the internals for cleaning and other maintenance operations.

Fans

- Asynchronous motors are used for air supply and exhaust.
- Centrifugal impeller with forward curved blades ensures high pressure and low noise level.
- Integrated overheating protection.
- Dynamically balanced impellers.
- Equipped with ball bearings for longer service life.

Heat exchanger

- The unit is equipped with two types of the plate cross-flow heat exchangers:
 - **Aluminium** heat exchanger recovers extract air sensible energy;
 - **Polymerized cellulose enthalpy** heat exchanger recovers sensible and latent energy of the extract air. These heat exchangers are frost-proof, produce no condensate and thus are recommended for operation in air conditioned premises.
- The air flows are fully separated within the heat exchanger. Odour and contaminants contained in the extract air are not transferred to the supply air flow.
- Heat recovery is based on utilization of heat energy contained in the

extract air stream for heating up of supply air stream. Extract air transfers most of its heat to the intake air flow. Heat recovery reduces heat energy losses in cold seasons. In summer the heat exchanger performs reverse and intake air is cooled in the heat exchanger by the cool extract air. This contributes to better performance of the air conditioner in ventilated premises.

- The integrated electronic frost protection system in **KOMFORT Ultra D105-A** is used to prevent the heat exchanger freezing in cold seasons. In case of heat exchanger freezing danger communicated by the temperature sensor the supply fan is stopped to let warm extract air warm up the heat exchanger. After that the the supply fan is turned on and the unit reverts to the normal operation mode.

Air filtration

- Two built-in cassette filters with filtration class G4 provide efficient supply and extract air filtration.

Control and automation

- Air flow control by the external speed switch CDP-3/5.
- The units has three fan speeds:
 - 1 speed – 57 m³/h, 24 dBA;
 - 2 speed – 78 m³/h, 32 dBA;
 - 3 speed – 106 m³/h, 41 dBA.

Mounting

- Indoor installation in horizontal position.
- Mounting in a false ceiling is possible due to compact casing size.
- A small air distribution network for central ventilation may be arranged based on the unit.
- The correct mounted unit must provide free access to the hinged side panel for servicing and filter replacement.

Technical data

Parameters	KOMFORT Ultra D105		KOMFORT Ultra D105-A
	I	II	III
Speed	I	II	III
Voltage [V / 50 Hz]	1 ~ 230		
Power [W]	30	38	56
Current [A]	0.18	0.23	0.34
Maximum air capacity [m ³ /h]	57	78	106
RPM	1300	1950	2500
Sound pressure level at 3 m [dBA]	24	32	41
Transported air temperature [°C]	-25 up to +50		
Casing material	aluzinc		
Insulating material	15 mm PE foam film		
Extract / supply filter	cassette G4		
Replaceable filter*	FP-Ultra D105 G4	FP-Ultra D105-A G4	
Duct connection diameter [mm]	125		
Weight [kg]	10	13	
Heat recovery efficiency [%]**	65-76	64-72	
Moisture recovery efficiency [%]**	up to 65	-	
Heat exchanger type	cross-flow		
SEC class	D		
Heat exchanger material	polymerized cellulose	aluminum	

*Replaceable filter kits are specially ordered accessories and are available on a separate order.
** Heat recovery efficiency is specified in compliance with the EN308 EU norms.

Overall dimensions

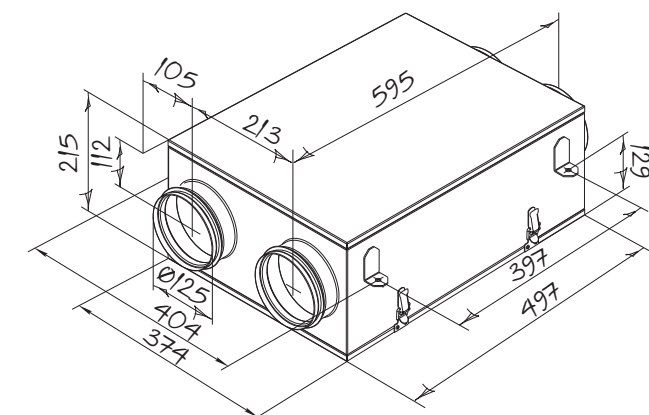

KOMFORT Ultra D105

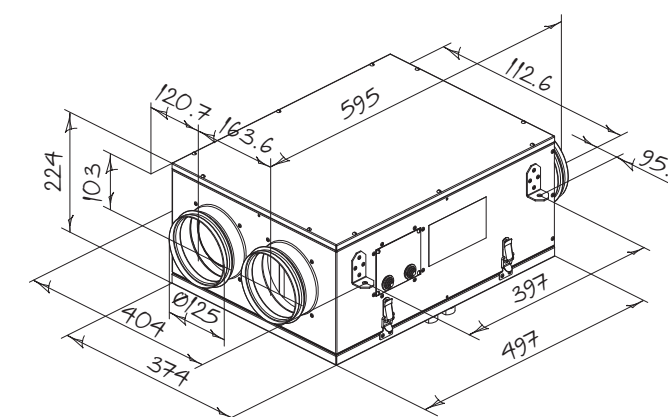

KOMFORT Ultra D105-A

